

IMAGE SHEET

RCD>PLY>RWD>FFWD>STOP>EJ

Curated by Aya Haidar

Private Preview: 13 October 2014

14 October – 22 November 2014

Artists:
Ibrahim Abumsmar
Doa Aly
Hazem Harb
Khaled Jarrar
Randa Mirza
Yara El-Sherbini
Ayman Yossri Daydban



Randa Mirza, *Beirut Is Back And It's Beautiful*, 2011, photograph, 80 x 120 cm
Image Courtesy of the artist and Kashya Hildebrand, London.



Ibrahim Abumsmar, *Al Qiblah Kite*, 2011, kite, 102 x 200 cm
Image Courtesy of the artist and Athr Gallery, Jeddah



Doa Aly, *Hysterical Choir Of The Frightened (HCF)*, 2014, 4K transferred to full HD,
single channel video projection, 3"51
Image Courtesy of the artist and Kashya Hildebrand, London.



Khaled Jarrar, *The Other Half*, 2013, reconstituted concrete from the Israel-Gaza wall
and olive tree, 34 × 15 × 13 cm

Image Courtesy of the artist and Kashya Hildebrand, London/Ayyam Gallery, Dubai,
London, Beirut, Damascus.



Ayman Yossri Daydban, *Al Qablah Al Oola (The First Kiss)*,
2014, Arabic comic on acid free paper, 77 x 56 cm
Image Courtesy of the artist and Athr Gallery, Jeddah



Hazem Harb, *Forever*, 2013, stainless steel, 150 x 50 x 50 cm.
Image Courtesy of the artist and Athr Gallery, Jeddah

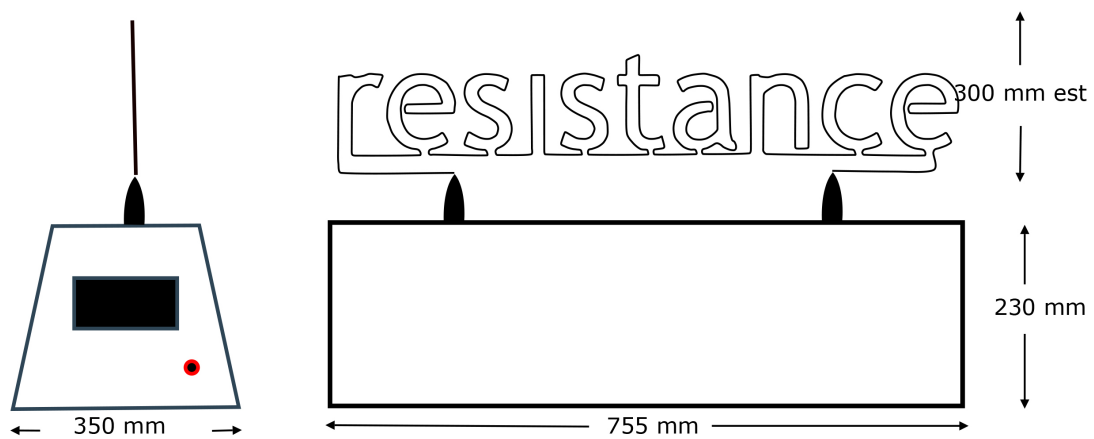
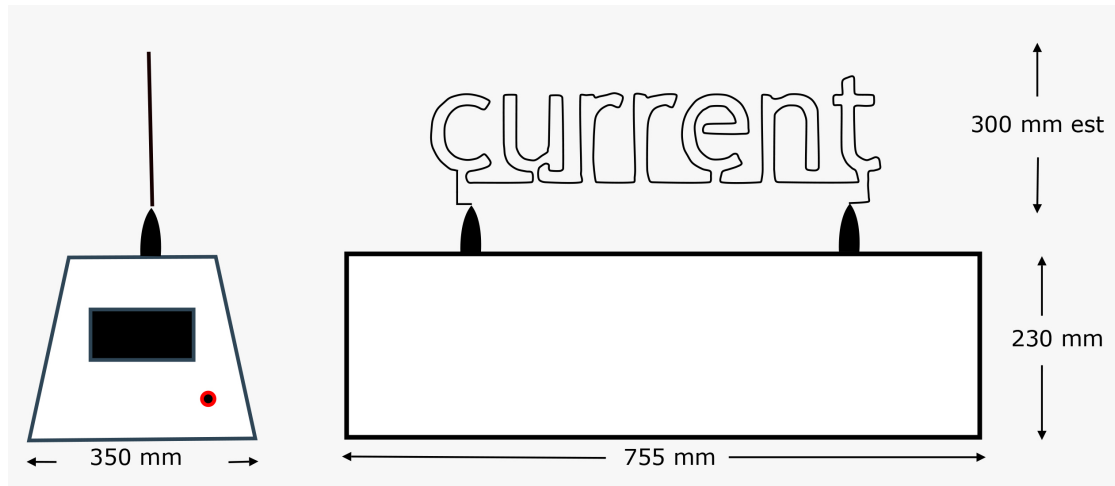

Yara El-Sherbini, (above) *Current* and (below) *Resistance*, from the *Buzzwords* series.
Both 2014, mixed media participatory sculptures, 75 x 35 x 55 cm each.
Image Courtesy the artist and Kashya Hildebrand, London.